

# 179084-15

(Varenr. 177061)



# PLUS

PLUS A/S

Ådalen 13B

DK-6600 Vejen

phone: +45 7996 3333

web: [www.plus.dk](http://www.plus.dk)

[plus@plus.dk](mailto:plus@plus.dk)

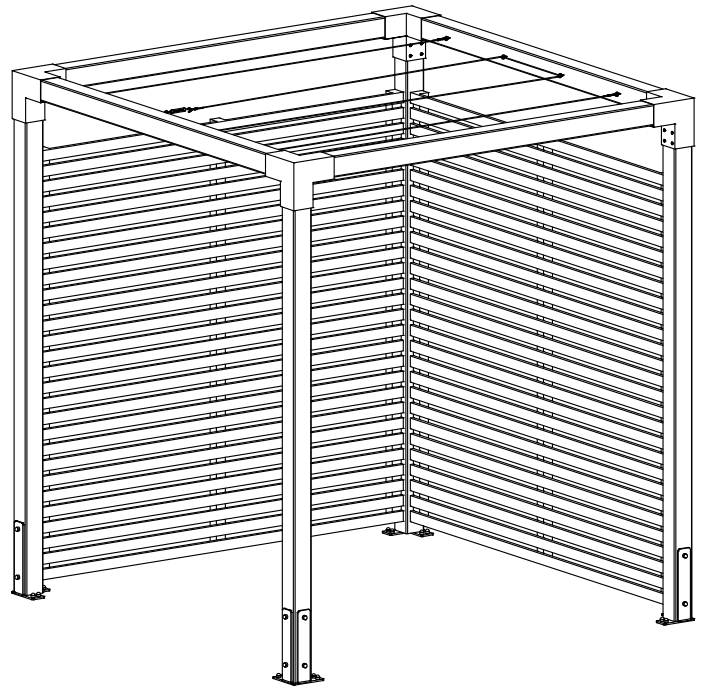
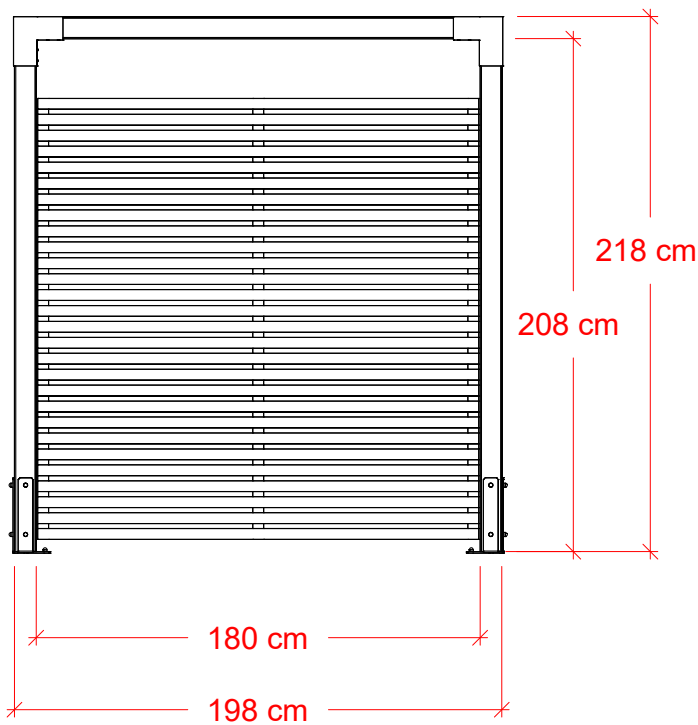

- DK: Vi anbefaler at være 2 personer til samling af dette produkt.  
Se [www.plus.dk](http://www.plus.dk) for yderligere information og vedligehold af materialer.
- SE: Vi rekommenderar 2 personer för att montera denna produkt.  
Se [www.plus.dk](http://www.plus.dk) för ytterligare information och underhåll av material.
- DE: Wir empfehlen 2 Personen für den Zusammenbau dieses Produkts.  
Weitere Informationen und Pflegehinweise finden Sie unter [www.plus.dk](http://www.plus.dk)
- UK: We recommend 2 people to assemble this product.  
[www.plus.dk](http://www.plus.dk) for further information and maintenance of materials.
- FR: Nous recommandons 2 personnes pour assembler ce produit.  
Voir [www.plus.dk](http://www.plus.dk) pour plus d'informations et d'entretien de matériel.

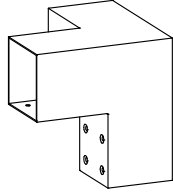
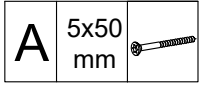
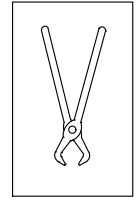
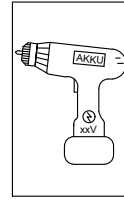
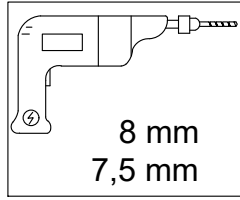
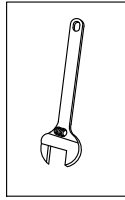
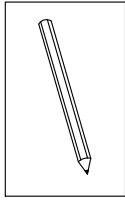
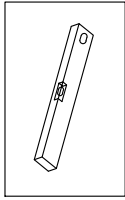
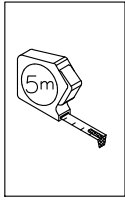

4 x  
17971-15

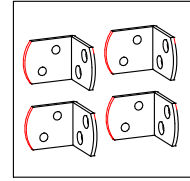
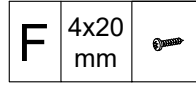

2 x  
0230-15

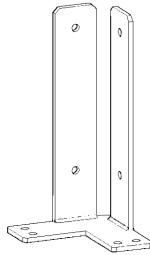
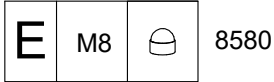
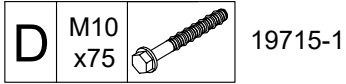
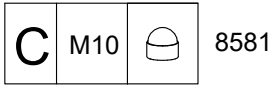
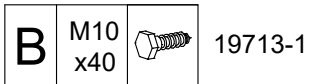
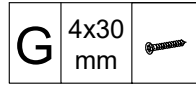

4 x  
1458-15

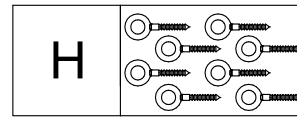

1 x  
8596

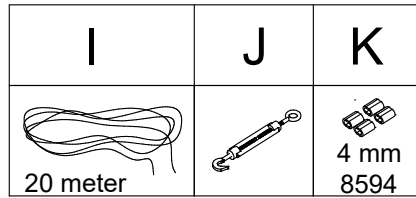

4 x 20467-15 (2080 mm)

4 x 20466-15 (1880 mm)

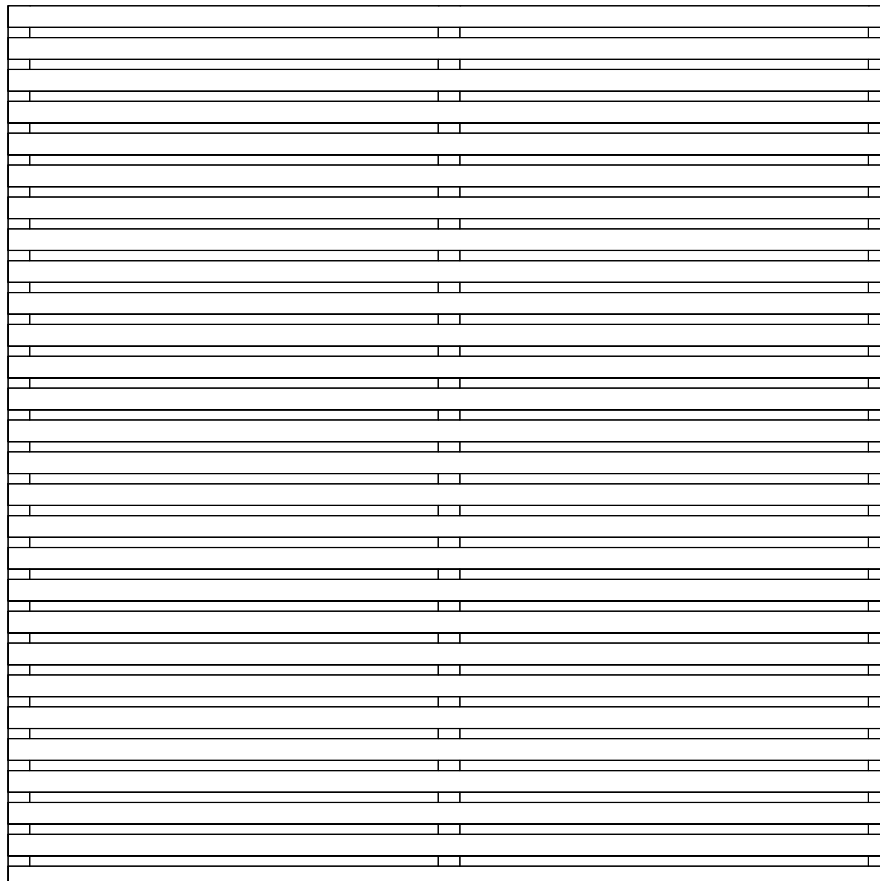

2 x  
17414-15

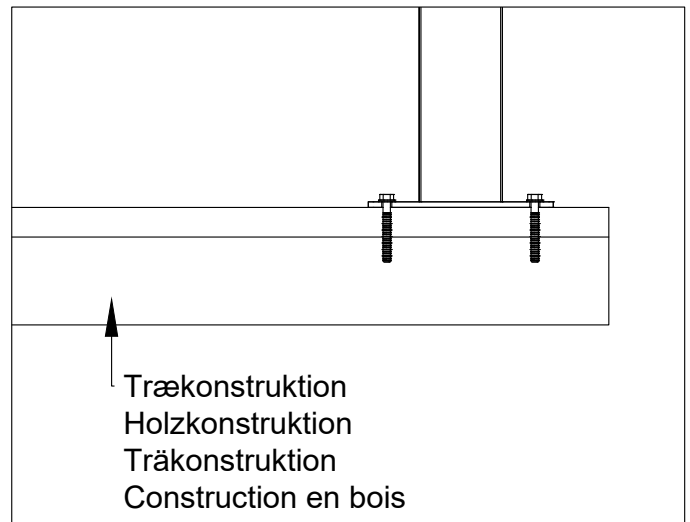
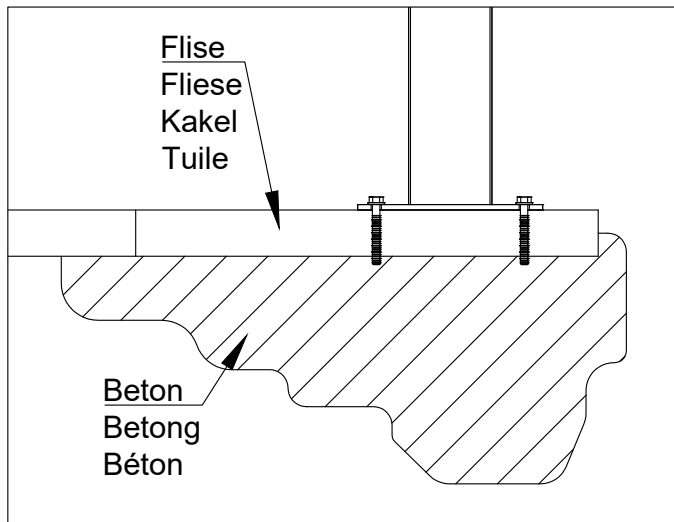

DK: Fastgørelse af stolper på fliser/fundament eller trækonstruktion.

I begge tilfælde SKAL fundamentskruerne ned og have fat i underkonstruktionen.

(Boltene monteres løst, så stolpen kan give sig lidt. Spændes fast, når pergolaen er helt samlet.)

SE: Fäste av stolpar på plattor/fundament eller träkonstruktion.

I båda fallen MÅSTE fundamentskruvarna gå ner och fästa i underkonstruktionen.

(Dra åt skruvarna löst, så att det går att vicka lite på stolpen. Dra sedan åt dem helt när pergolan är färdigmonterad.)

DE: Befestigung von Pfosten an Betonplatten/Fundament oder Holzkonstruktion.

In beiden Fällen MÜSSEN die Fundamentschrauben unten bis in die Unterkonstruktion greifen.

(Die Bolzen werden lose montiert, damit der Pfosten etwas Spiel hat. Sie werden festgezogen, wenn die Pergola vollständig montiert ist.)

UK: Fastening posts to tiles/foundation or wooden structure.

In both cases, the foundation screws MUST go down and engage the substructure.

(The bolts are installed loosely so that the post can give a little. Tighten when the pergola is fully assembled).

FR: Fixation de poteaux sur des dalles/des fondations ou une construction en bois.

Dans les deux cas, les vis de fondation DOIVENT être vissées suffisamment profondément pour attraper la sous-structure.

(Ne serrez pas trop les boulons de sorte que le poteau ait un peu de jeu. Serrez-les une fois la pergola complètement assemblée.)

\* Beton forbores med Ø8 mm bor og træ forbores med Ø7,5 mm bor.

\* Betong förborras med Ø8 mm borrh och trä förborras med Ø7,5 mm borrh.

\* In Beton muss mit 8 mm vorgebohrt werden und in Holz mit 7,5 mm.

\* Pre-drill concrete with Ø8 mm drill bit and pre-drill wood with Ø7.5 mm drill bits.

\* Le béton est pré-percé avec un foret Ø8 mm et le bois est pré-percé avec un foret Ø7,5 mm.

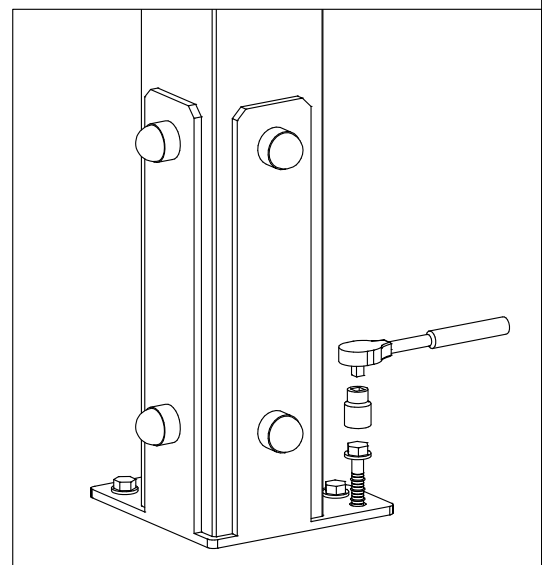

20467-15 (2080 mm)

x 4

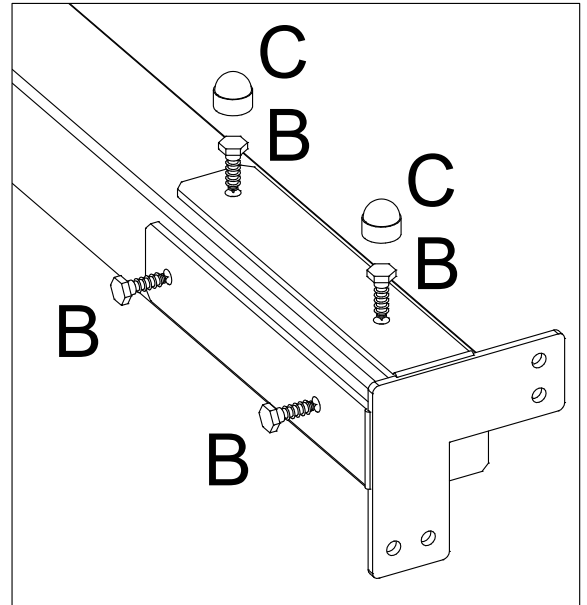

13 mm  
17 mm

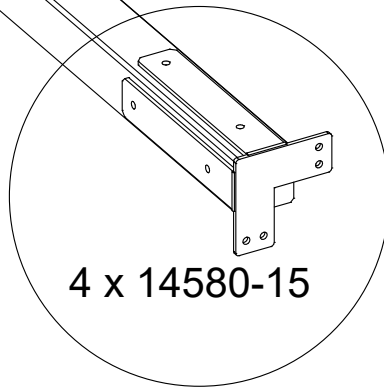

4 x 14580-15

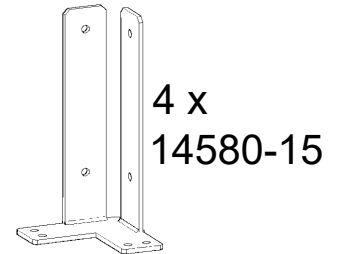

4 x  
14580-15

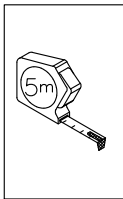
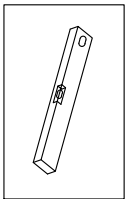

DK: Vigtigt at kontrollere krydsmålet inden stolperne skrues fast.

SE: Det är viktigt att kontrollera krydsmåttet innan stolparna skruvas fast.

DE: Es ist wichtig, das Kreuzmaß zu überprüfen, bevor die Pfosten eingeschraubt werden.

UK: Important to check the cross measurement before screwing in the posts.

FR: Il est important de vérifier la mesure transversale avant de visser les poteaux.

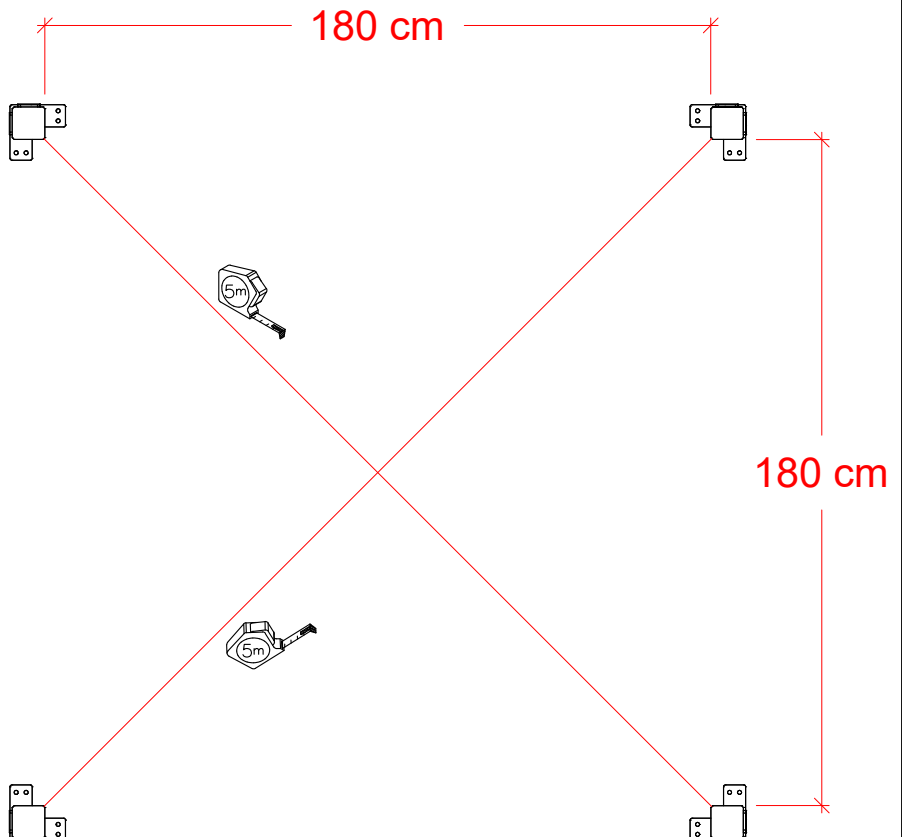

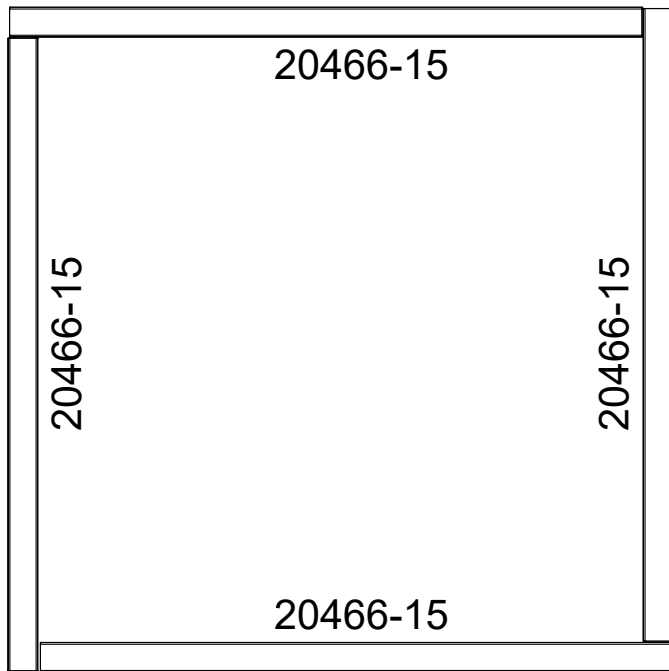

DK: **Sådan placeres overliggerne.**

Skrues løst sammen med hjørne beslagene og løftes forsigtigt samlet på plads. (Samles med stolperne).

SE: **Hur man placerar överliggarna.**

Skruva löst ihop med hörnfästena och lyft försiktigt monteringen på plats. (Monterad med stolparna).

DE: **Wie man die Stürze anbringt.**

Schrauben Sie die Eckwinkel lose zusammen und heben Sie die Baugruppe vorsichtig an ihren Platz. (Zusammengebaut mit den Pfosten).

UK: **How to position the lintels.**

Screw loosely together with the corner brackets and carefully lift the assembly into place. (Assembled with the posts).

FR: **Comment positionner les linteaux.**

Visser sans serrer les supports d'angle et soulever avec précaution l'ensemble pour le mettre en place. (Assemblé avec les poteaux).

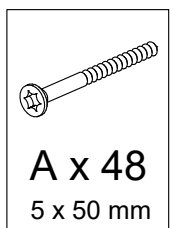
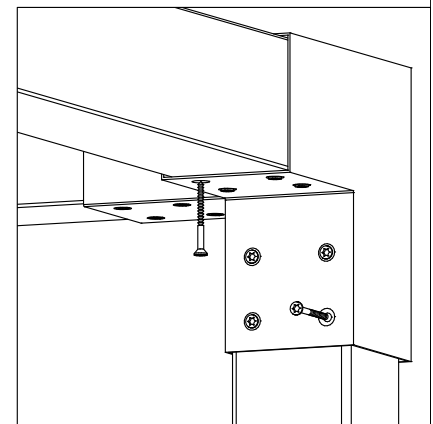
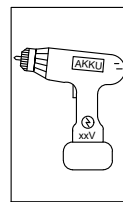

Se side 6.  
Se sidan 6.  
Siehe Seite 6.  
See page 6.  
Voir page 6.

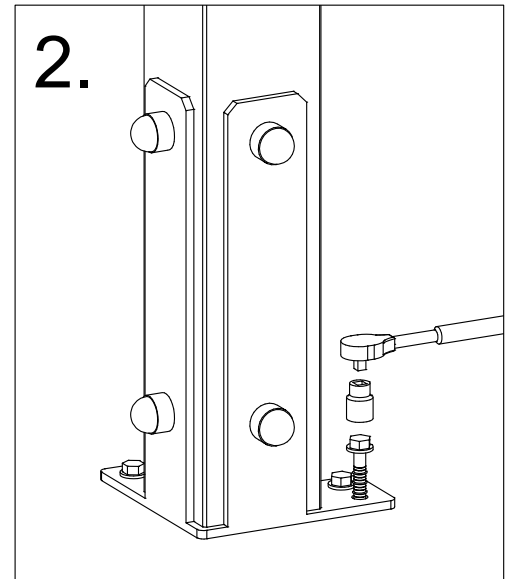
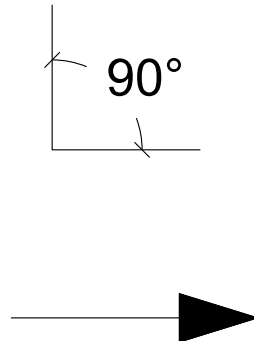
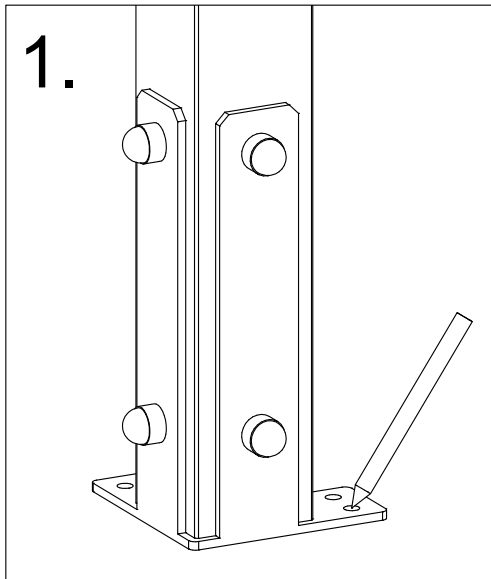
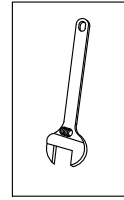
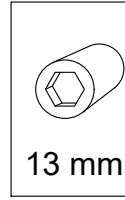
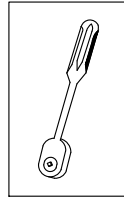
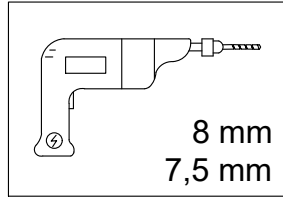
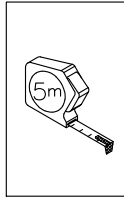
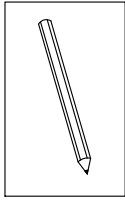
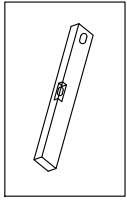

DK: Stolpeplan: Se krav til underkonstruktionen og placering på **side 4**.

SE: Stolpplan: Se krav på underkonstruktion och placering på **sidan 4**.

DE: Pfostenplan: Siehe Anforderungen an die Unterkonstruktion und Platzierung auf **Seite 4**.

UK: Post level: See substructure requirements and placement on **page 4**.

FR: Plan des poteaux : Voir les exigences et l'emplacement de la sous-structure à la **page 4**.

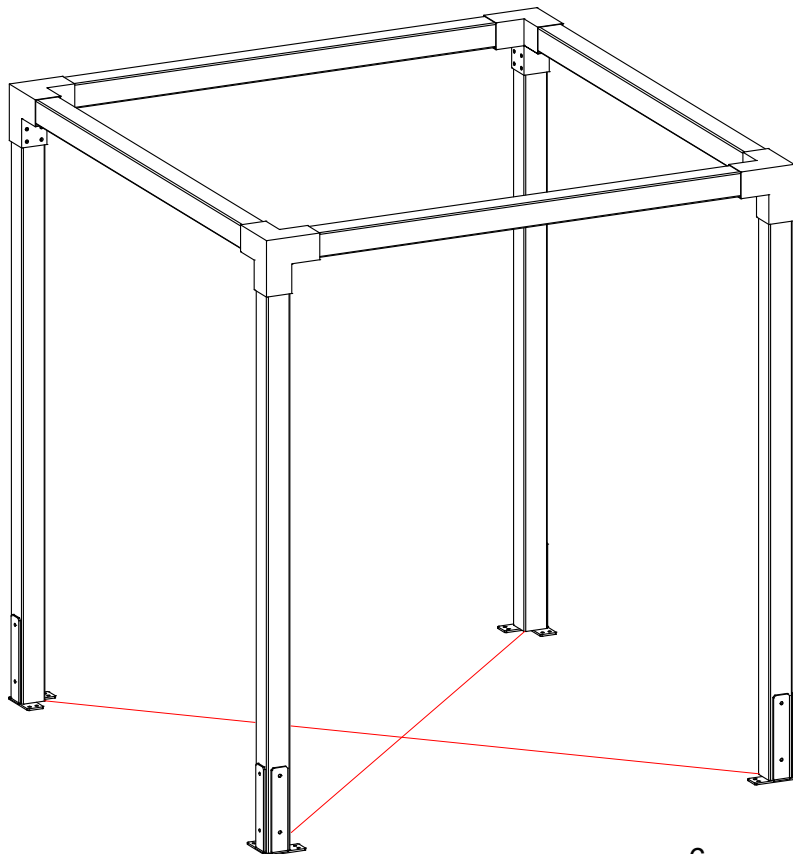

DK: Skruer strammes til, når **ALLE** dele er færdig samlet.

SE: Skruvarna dras åt när **ALLA** delar är monterade.

DE: Ziehen Sie die Schrauben fest, wenn **ALLE** Teile zusammengebaut sind.

UK: Tighten screws when **ALL** parts are fully assembled.

FR: Serrez les vis une fois que **TOUTES** les pièces sont assemblées.

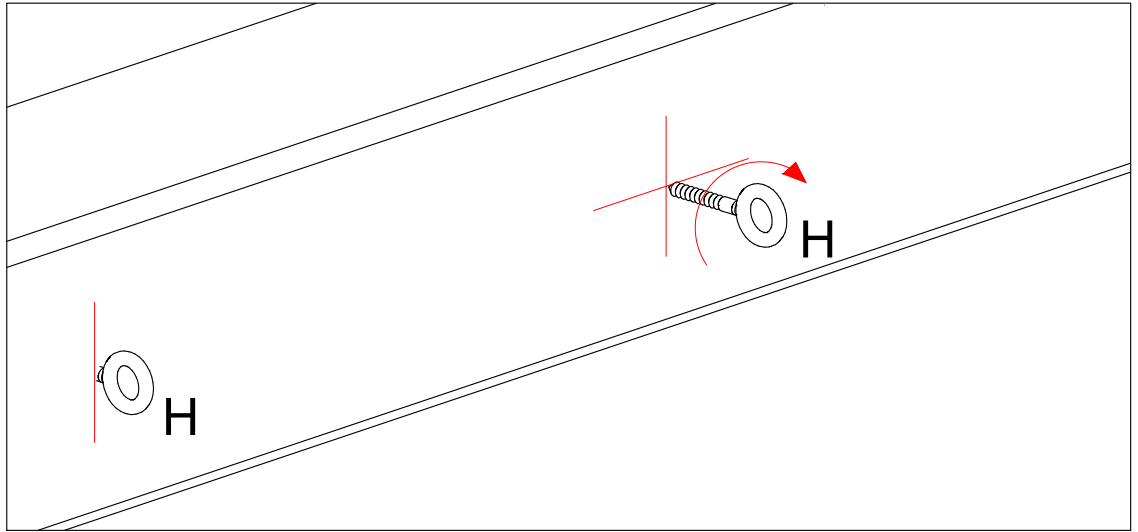
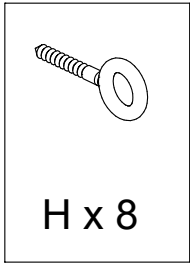
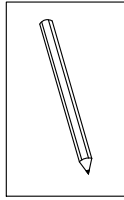
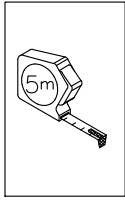
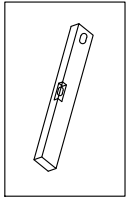

x 2

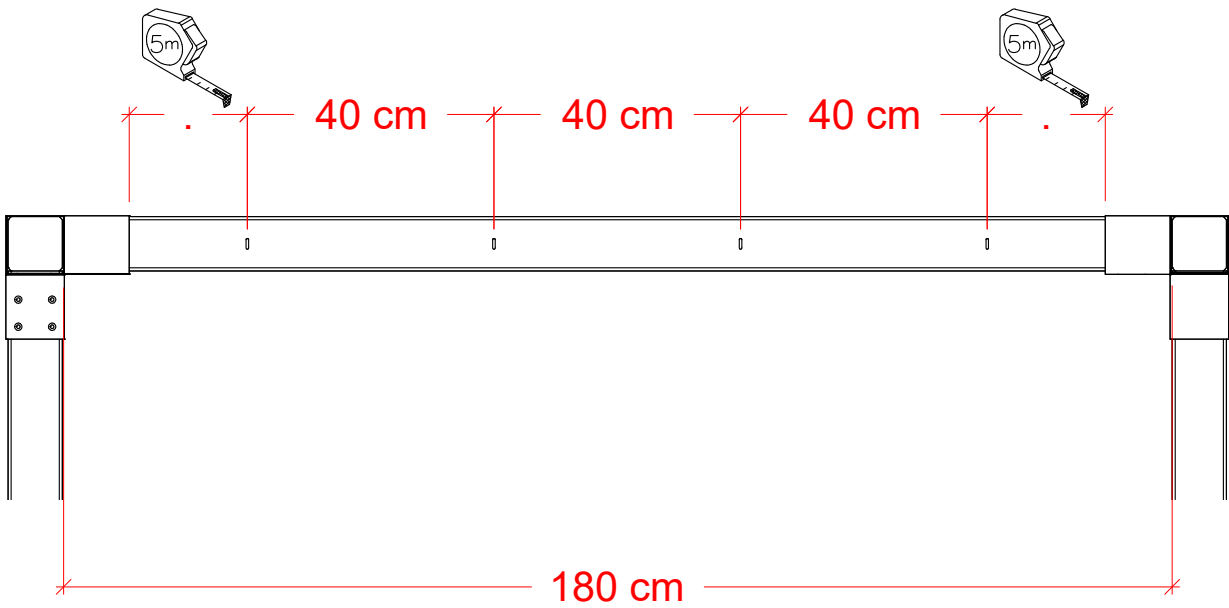

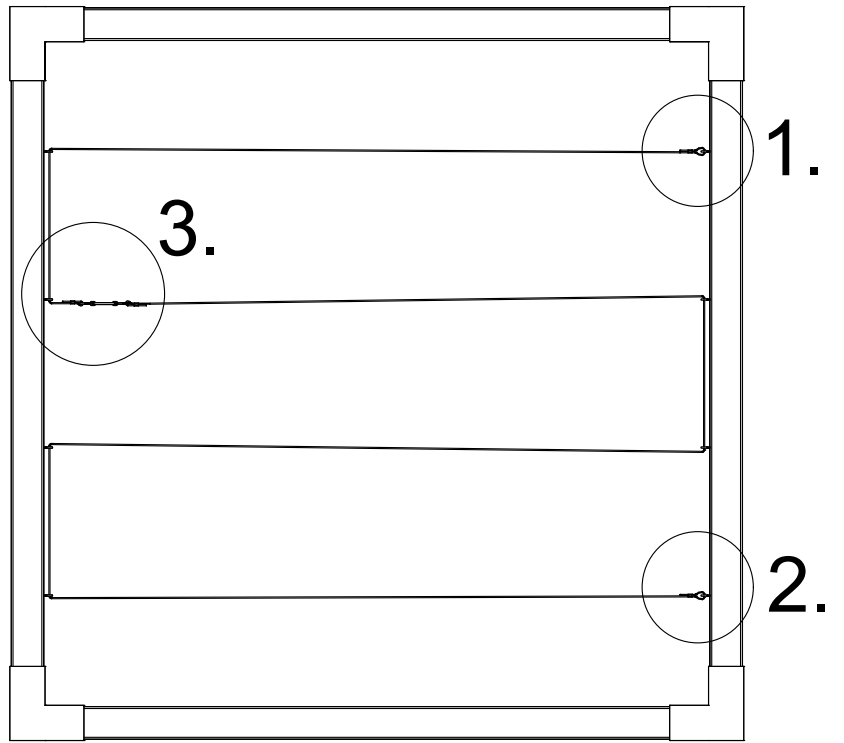
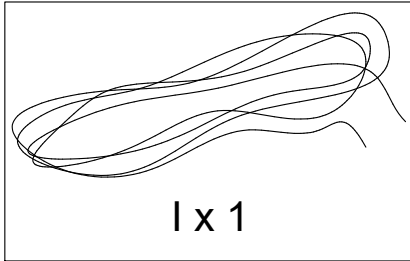
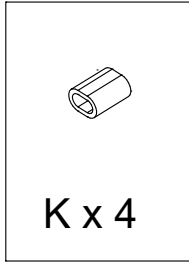
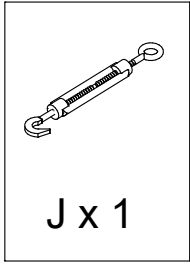

DK: Snoren klippes til - se tegning.

SE: Klipp av snöret - se ritning.

DE: Schneiden Sie die Schnur ab - siehe Zeichnung.

UK: Cut the string - see drawing.

FR: Couper la ficelle - voir dessin.

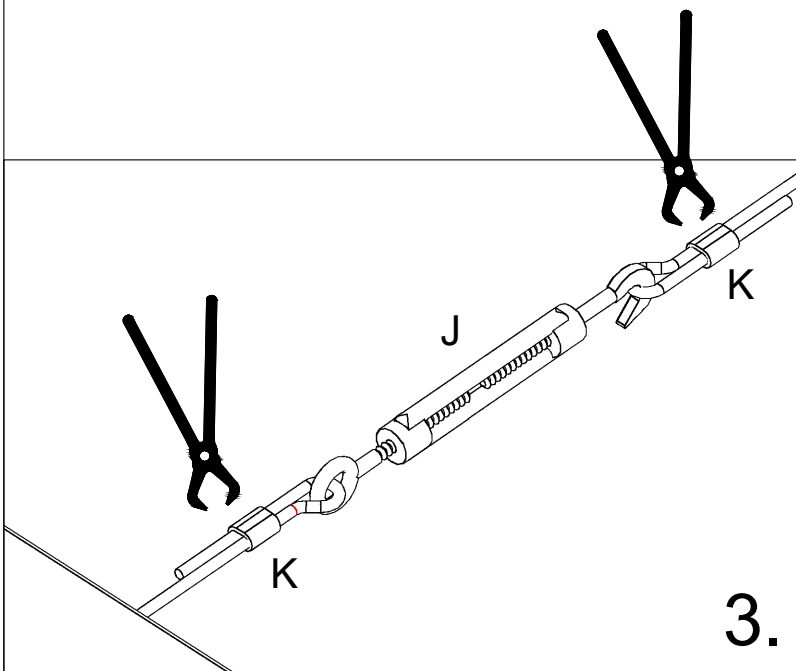
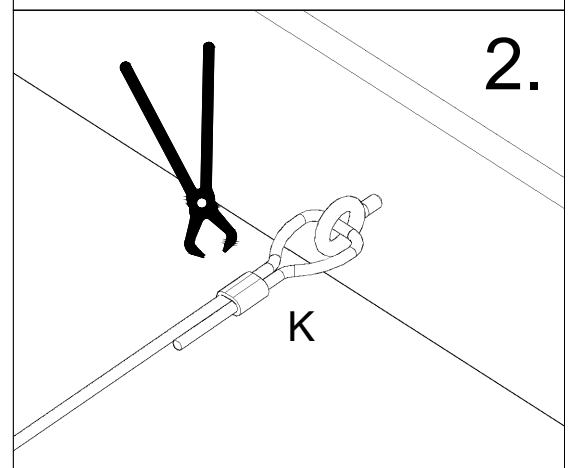
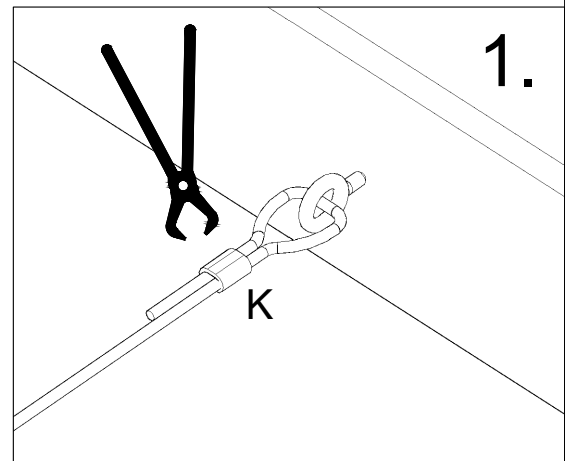

→  
Se side 9.  
Se sidan 9.  
Siehe Seite 9.  
See page 9.  
Voir page 9.





DK: Tørresnoren "brændes" i enderne, så den ikke trævler.

SE: Klädlinan är "bränd" i ändarna för att förhindra att den fransar sig.

DE: Die Trocknungsleine ist an den Enden "verbrannt", damit sie sich nicht auflöst.

UK: The clothesline is 'burnt' at the ends to prevent it from fraying.

FR: La corde à linge est « brûlée » aux extrémités pour éviter qu'elle ne s'effiloche.

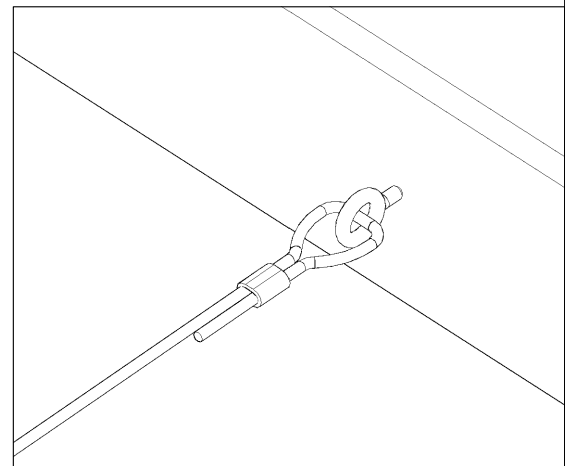
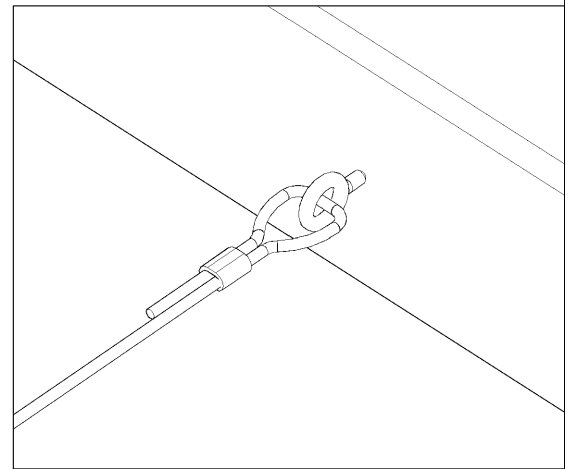
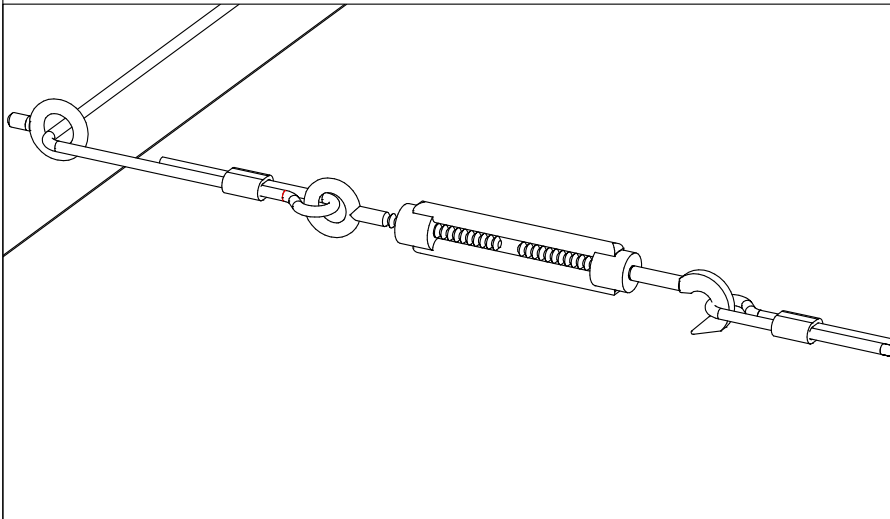

DK: Alt bør efterspændes med jævne mellemrum.  
Se [www.plus.dk](http://www.plus.dk) for yderligere information og vedligehold af materialer.

SE: Allt bör efterspännas med jämna mellanrum.  
Se [www.plus.dk](http://www.plus.dk) för ytterligare information och underhåll av materialet.

DE: Alles sollte in regelmäßigen Abständen angezogen werden.  
Weitere Informationen und Pflegehinweise finden Sie unter [www.plus.dk](http://www.plus.dk)

UK: Everything should be tightened at regular intervals.  
See [www.plus.dk](http://www.plus.dk) for further information and maintenance of materials.

FR: Le tout doit être resserré à intervalles réguliers.  
Consultez [www.plus.dk](http://www.plus.dk) pour plus d'informations sur l'entretien des matériaux.

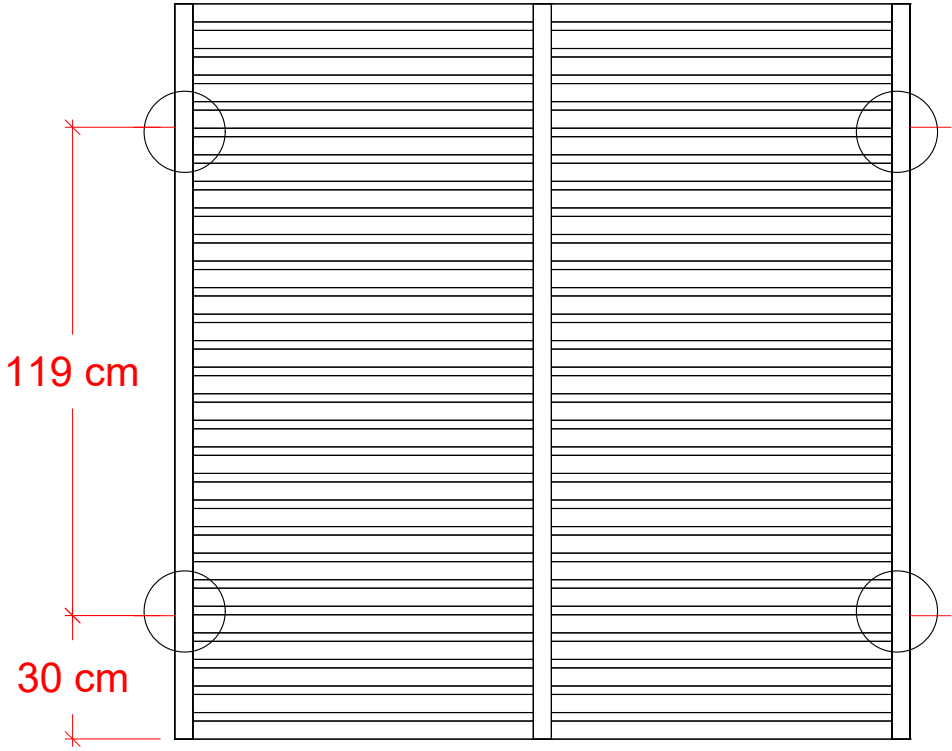

**0230-15**

	<b>F x 8</b> 4 x 20
	<b>G x 8</b> 4 x 30

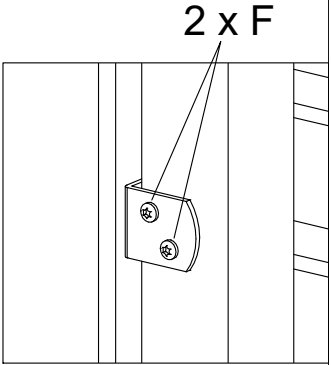

1.

2.

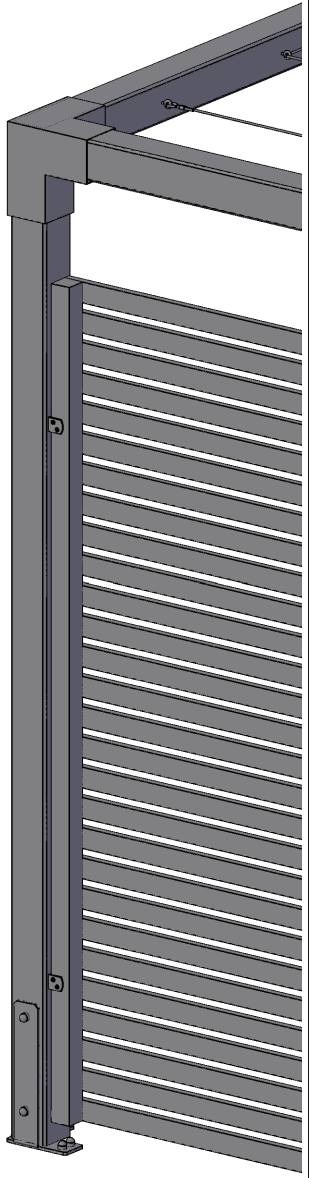
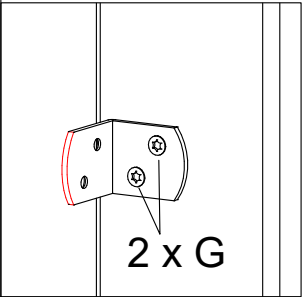
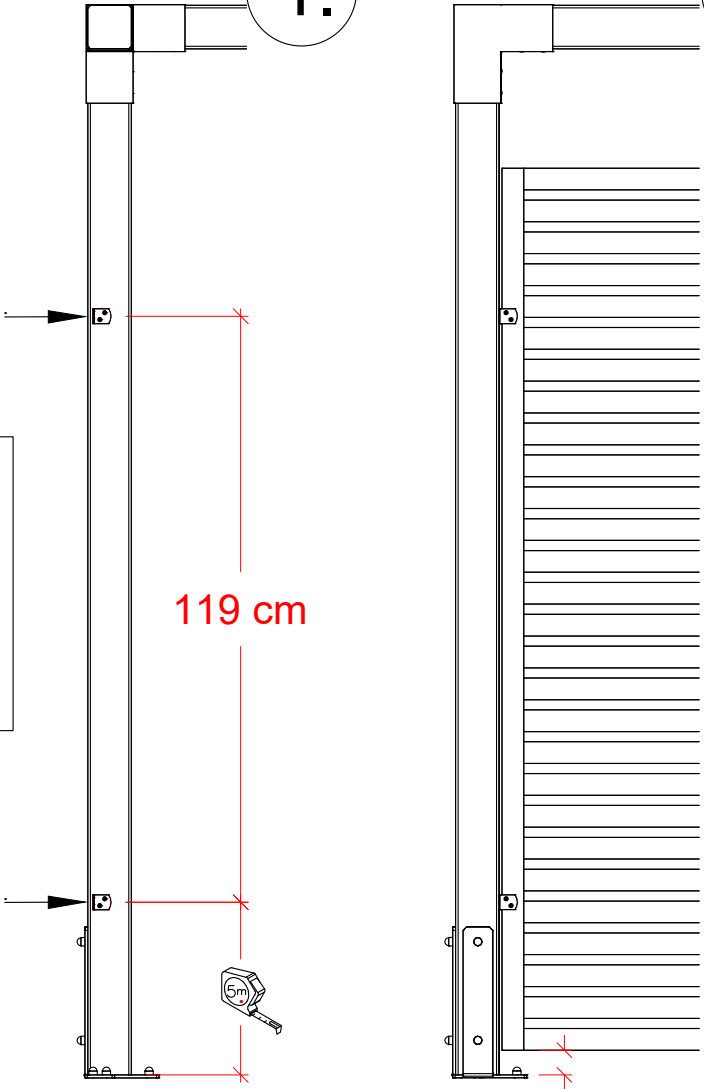

5 cm

## 0230-15

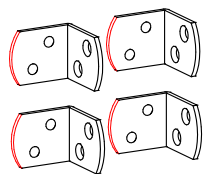

F x 8  
4 x 20

G x 8  
4 x 30

DK: Hegn 2 monteres på samme måde som hegn 1.

1. Beslag monteres på stolpe.
2. Hegn skrues fast.

SE: Staket 2 monteras på samma sätt som staket 1.

1. Montera fästet på stolpen.
2. Skruva fast staketet på plats.

DE: Der Zaun 2 wird auf die gleiche Weise wie der Zaun 1 montiert.

1. die Halterung am Pfosten montieren.
2. Schrauben Sie den Zaun an seinen Platz.

UK: Fence 2 is installed in the same way as fence 1.

1. Mount the bracket on the post.
2. Screw the fence in place.

FR: La clôture 2 s'installe de la même manière que la clôture 1.

1. Monter le support sur le poteau.
2. Visser la clôture en place.

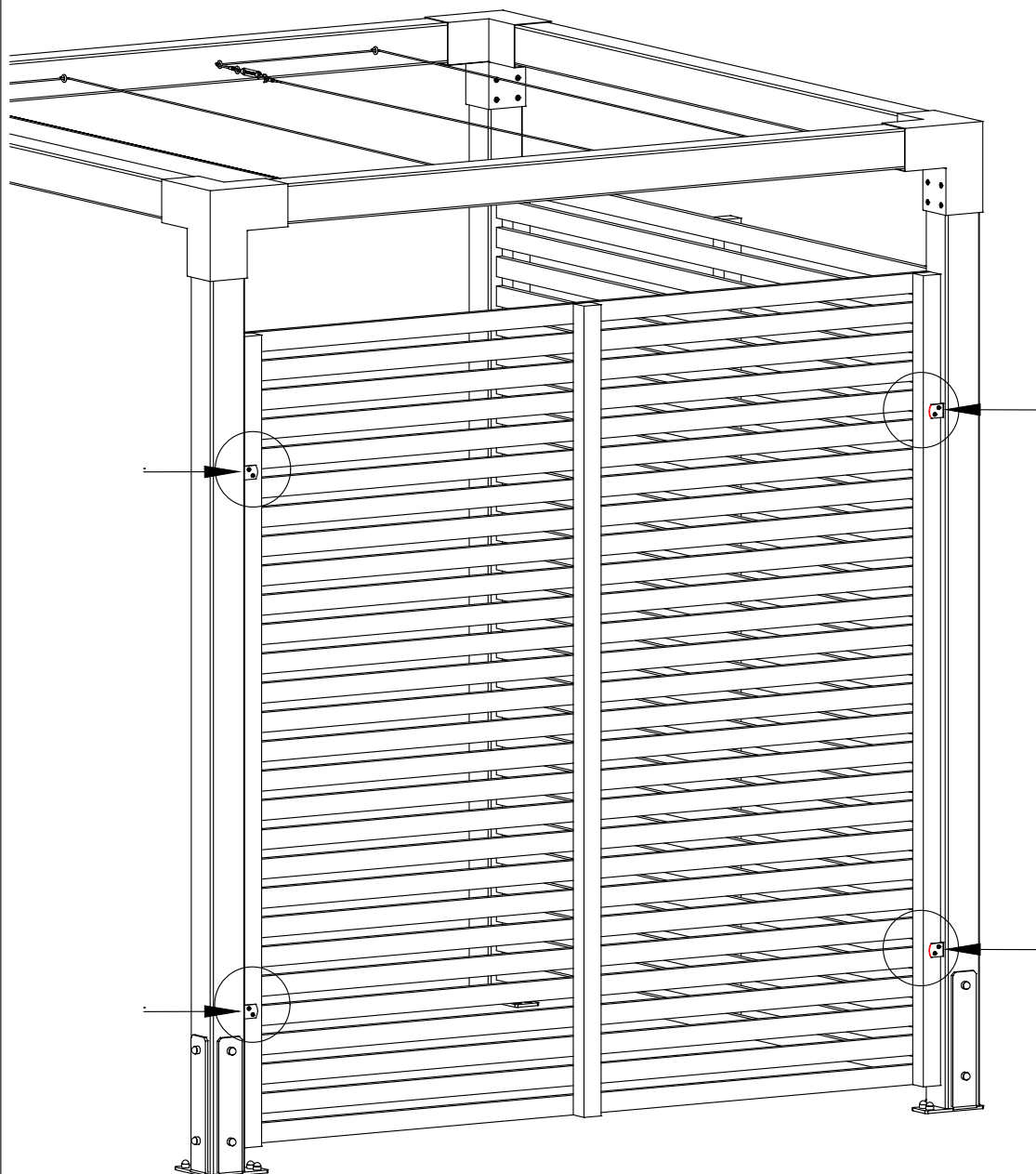

1.

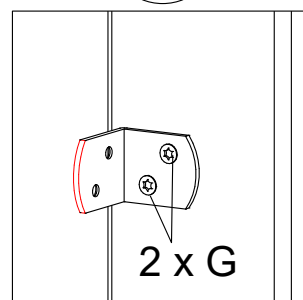

2 x G

2.

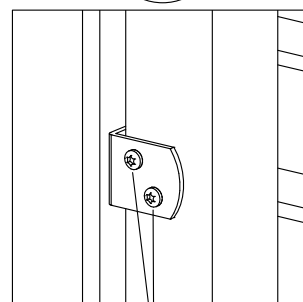

2 x F

179084-15

